

6

5

4

3

2

1

D

C

B

A

D

C

B

A

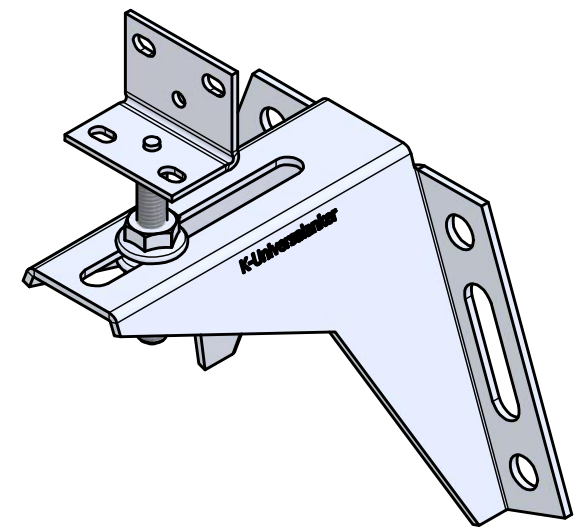
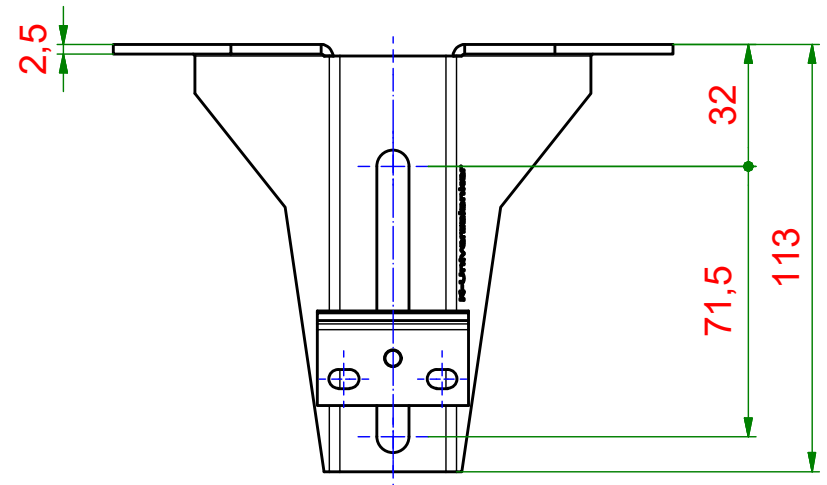
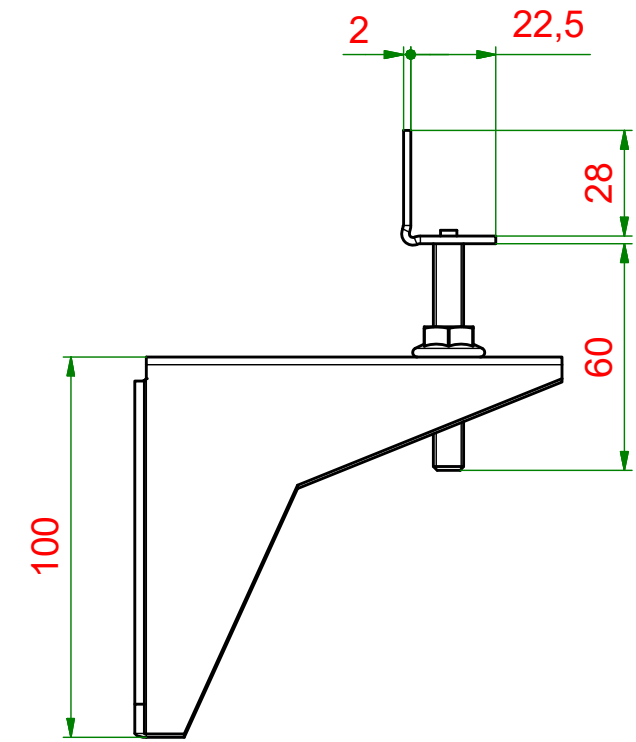
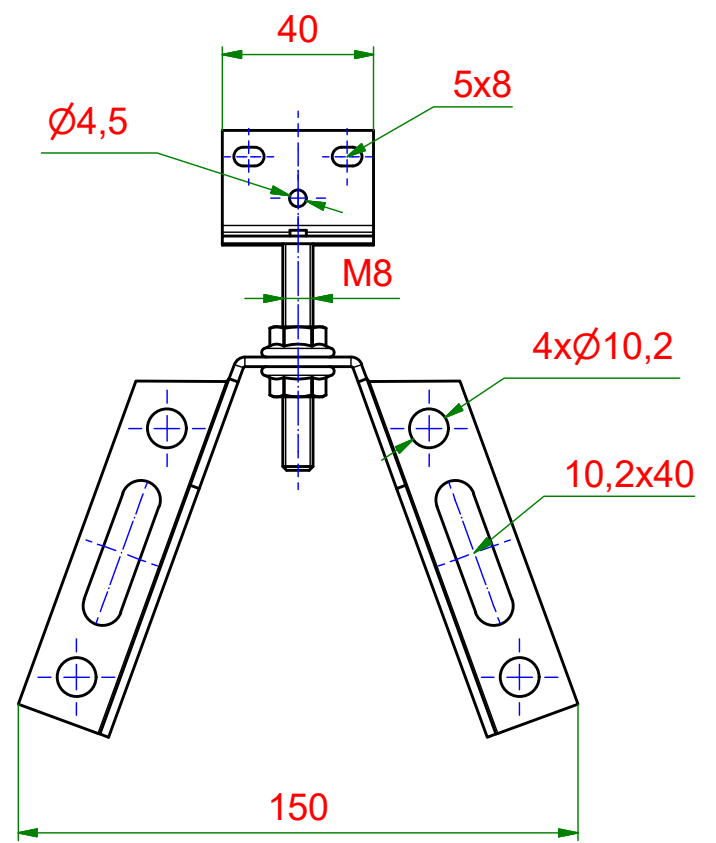

KNELSEN Entwicklung und Herstellung Knelsen GmbH Am Schlinge 26 33154 Salzkotten Tel.: 05258 / 93766-95 Fax: 05258 / 93766-97 www.knelsen.de info@knelsen.de		Material: verzinkter Stahl		
		Maßstab: 1 : 2	Masse: 0,4 kg	
	Erstellt 30.10.2020 Genehmigt	Datum Name R.Heiermeier	Titel, Beschreibung WS-110x110-W60 WS-Konsole	
	Allgemeintoleranzen nach ISO 2768-m Schutzvermerk nach DIN ISO 16016 beachten		Bauteilnummer / Zeichnungsnummer 405078	Blatt 1 A3

6

5

4

3

2

1